



# SaunaFin

Saunas & Steambaths

**PLUS EP - PURE & ELITE (WITH QSG & FULL MANUAL)**  
APRIL 2023



**Sense Plus EP with Pure or Elite Control QSG (Quick Start Guide)**

**Please use this QSG ONLY to install this sauna heater.**

**Keep full manual for later reference and trouble-shooting.**



**240-volt, single phase**

Model	Output (kW)	Copper Wire size	Amps	Breaker
Sense Plus 7	7	8	29.2	40
Sense Plus 8	8.3	8	34.6	50

Note: Heater rating label shows input for 208v and 240v. Heating elements do not change. The heater output will change based on the voltage applied to heater.

Typical home in USA & Canada is 240-volt, single phase.

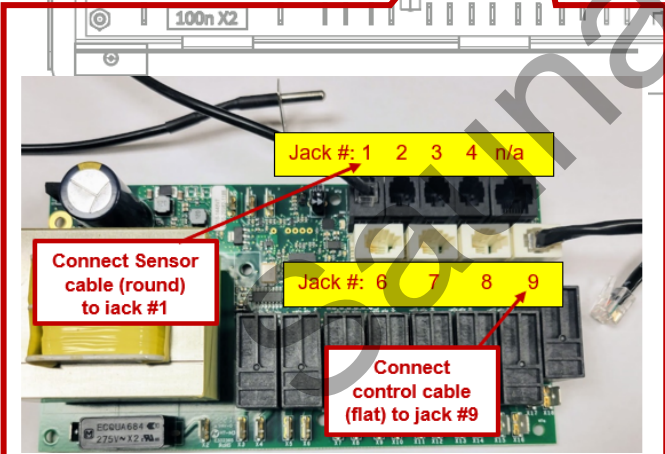
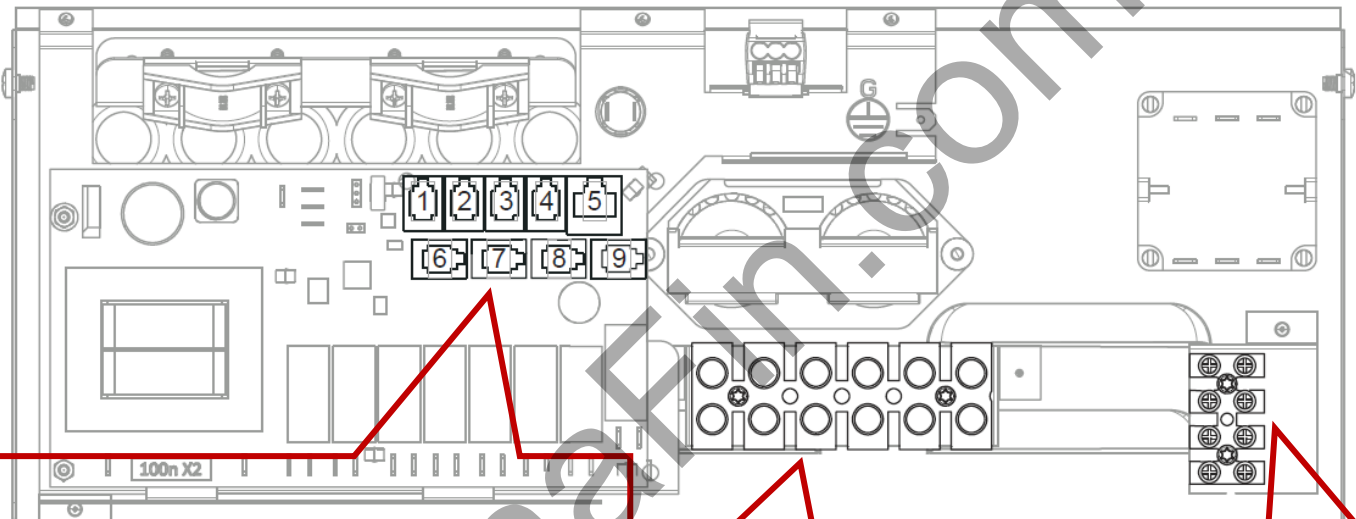

Standard control cable length is 15 feet. Longer available for order if required. We discourage splicing or trying to make your own longer cable.

Sensor cable is standard 15'. No option. No need for longer as specified location is close to heater.

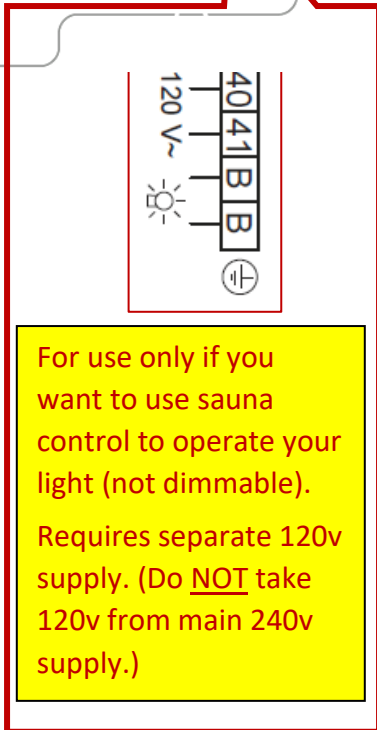
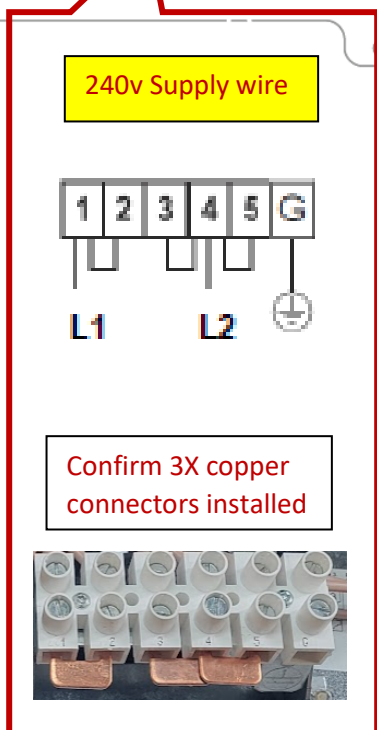

Heater junction box is a tight fit. Ensure no bare wires make contact with circuit board, or other heater components. When closing junction box cover to ensure wires are not being pushed out of position or trapped in cover.

Some prefer or are required to make a weather-proof connection. You may use Liquid tight conduit for the wire exposed within the sauna. For more flexibility, you can install weather proof junction box inside sauna below heater and use flexible SOOW wire to connect to heater

## Temperature Sensor Location

**Sensor location is very specific and very important for proper function of the sauna heater. Sensor must be 3" to the front or open side of heater (not in corner), 1" down from ceiling.**

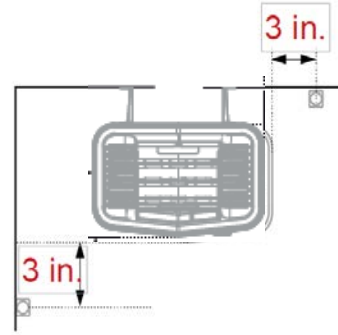
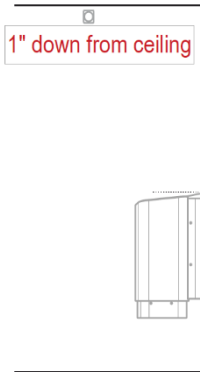

## Temperature Sensor Installation

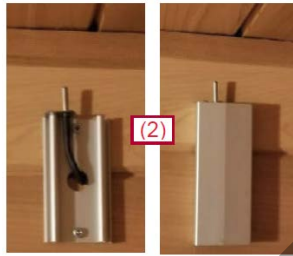
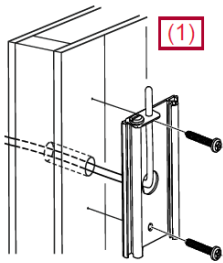

1. Using Sensor Cover: To hide cable inside wall cavity, you must first feed the sensor wire through the sensor holder, then run wire inside the wall, down to area where heater is to be installed.
2. Sensor tip mounts to top of sensor, 1" maximum down from ceiling. Place cover over holder, making sure not to cover sensor itself.
3. Do NOT mount sensor holder on top of sensor after the fact. (This can affect sensor reading and affect sauna operation).
4. Many choose to install bare sensor without holder and cover. Arguably, this is optimal installation as sensor is fully exposed to air temp, not metal (cover) and more accurately reflects air temperature.

## SAUNA VENTILATION

**Indoor Sauna: Position the air inlet and outlet vents as far away from one another as possible (diagonally opposite). The outlet vent should be located high on a wall (A), and should be about 19" sq. should be directed back into house – it should not be discharged directly to the outside.**  
**If outlet wall is inaccessible, install outlet vent in far corner of ceiling. Duct over drop ceiling to area in front of sauna (B).**  
**Outdoor Saunas: Outdoors generally have easy access. Some choose to hold off on vents initially and add later if it appears to be necessary.)**  
**Do not install inlet and outlet vents on same wall. Bad ventilation can be worse than no ventilation.**

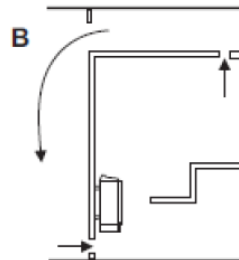
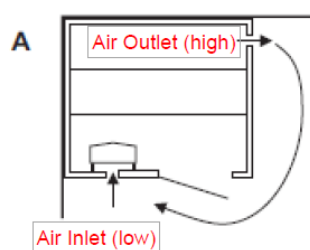
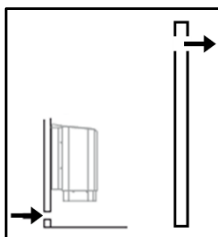



## Heater Installation

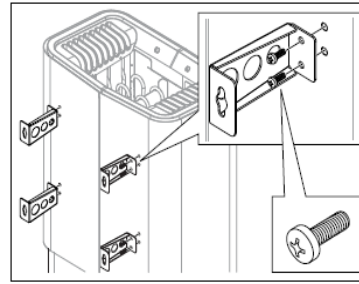
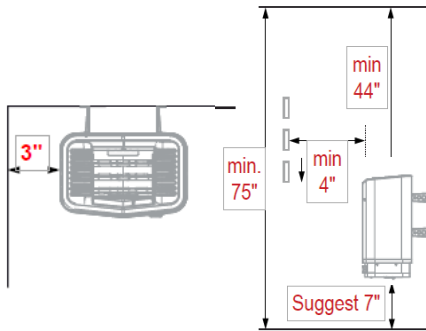

Attaching the brackets to the heater

Unscrew the first two screws on the back of the heater and screw bracket to heater one at a time. Note: If all the screws on the back are unscrewed simultaneously, the back plate may come loose.

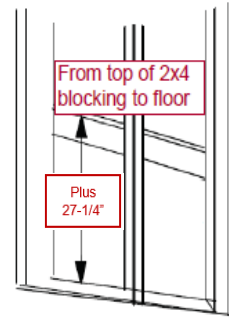

Secure bracket thru lining into blocking. Otherwise, heater may fall off wall.

1. Minimum distance from side wall: 3" (75 mm)
2. Minimum distance from ceiling: 44" (1100 mm)
3. Minimum from heater guard (front): 4" (100 mm)
4. Minimum from heater guard (side): 2" (50 mm)
5. Minimum ceiling height: 75" (1900 mm)
6. Distance from floor: 7" (175 mm)

**NB: If all the screws on the back are unscrewed simultaneously, the back plate may come loose. For this reason, attach the four brackets to the heater one at a time.**



## PURE 2.0 & ELITE Wi-Fi CONTROL INSTALLATION INSTRUCTIONS

The control panel can be installed inside or outside the sauna room. **If the control is installed inside the room, install no higher than 3' (90 cm) above the floor. No closer than 12" (30 cm) to heater.**

Before applying the control to the wall, connect it to the heater and electrically test everything first.

### INSTALLATION WITHOUT BRACKET

Cut a 1-3/16" (3 cm) hole through the wall big enough for the control panel connector. Clean the surface where the control will be applied to remove all dust. Attach the double-sided adhesive to the control panel. Remove the protective backing from the adhesive and press the control panel firmly to the wall. Silicone sealant can be applied as an extra seal.

### INSTALLATION WITH BRACKET

Use the mounting bracket as a template to mark screws holes on the wall. Cut a 1-3/16" (3 cm) hole through the wall big enough for the control panel connector. (If control cable to be surface mounted, connector can be fitted in back of mounting bracket.) Use adhesive to mount the control to the bracket.



See Control box for instructions on how to operate control.



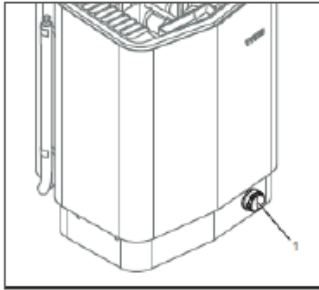

**Main Power Switch: On/Off Knob** comes packed inside rock tray. Field install. Turn knob to turn on heater.

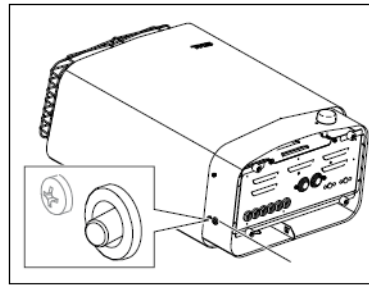

**Resetting the temperature cut-out**

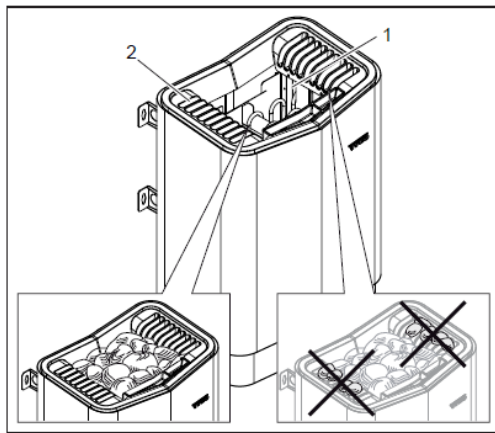
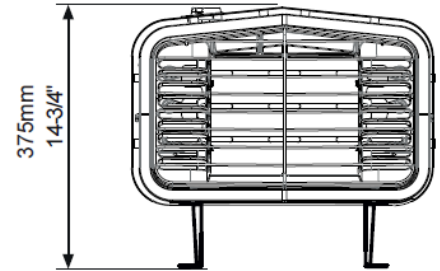
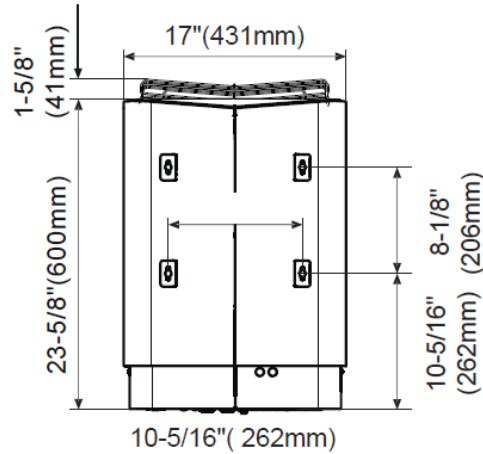
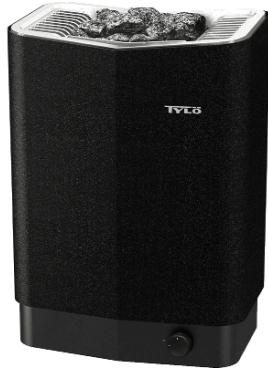

**Very Important:**

**Clean rocks before use to remove dust.**

**Sauna rocks may only be placed in center (deep) rock compartment (1). Never place stones on top of the side air chambers (2). This will obstruct air circulation, causing the unit to overheat and the cut-out switch to activate.**

**First Use:**

Turn on heater for one hour to "burn off" any new paint or element oils. The water reservoir does not need to be operating. There may be a little smoke initially. This is normal.

**Annually**

Check stone compartment. Remove all stones. Remove all small stones, gravel and lime-scale from rock compartment. Replace damaged stones with new ones as required.

# SENSE PURE/ELITE USA-EP

ENGLISH

## INSTALLATION / USER GUIDE

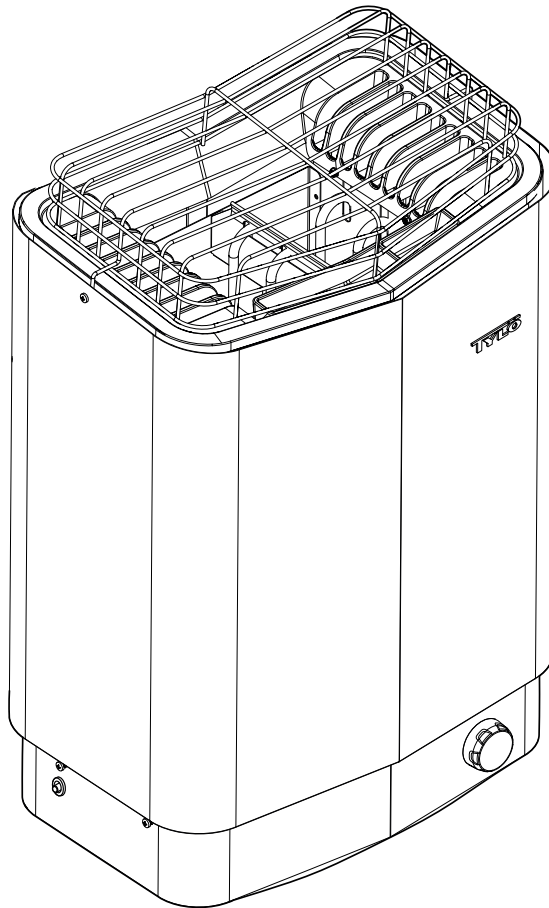

**INSTALLATION GUIDE.....3****BEFORE INSTALLATION .....3**

Parts .....	3
Installation requirements .....	3
Installation tools .....	3
Installation planning .....	3

**INSTALLATION ..... 6**

Sauna heater installation .....	6
External ON/OFF switch (option) .....	7

**CONNECTION/WIRING ..... 8**

Description of cabling/modular contacts .....	9
-----------------------------------------------	---

**SELF-INSPECTION OF THE INSTALLATION..... 9****DIMENSIONS..... 10****USER GUIDE..... 11****GENERAL INFORMATION .....11****PRIOR TO USE .....11**

The first time you use the heater .....	11
Prior to each use .....	11

**USE .....12**

The control panel in general.....	12
Other functions.....	12

**EXTERNAL ON/OFF SWITCH (OPTION).....12****AFTER USE .....12**

Empty the reservoir.....	12
Switch off main power switch.....	12

**MAINTENANCE .....12**

Cleaning the fragrance holder and air humidifier.....	12
Check the stone compartment .....	12

**TROUBLESHOOTING .....13**

Troubleshooting the control panel .....	13
Troubleshooting the sauna heater.....	14

**SPARE PARTS LIST .....15****ROHS (RESTRICTION OF HAZARDOUS SUBSTANCES) ..... 15****HEATER WIRING DIAGRAM .....16****WARNING!**

\* **Hyperthermia** occurs when the internal temperature of the body reaches a level several degrees above the normal temperature of 98.6° F. The symptoms of hyperthermia include an increase in the internal temperature of the body, dizziness, lethargy, drowsiness and fainting. The effect of hyperthermia include:

- Failure to perceive heat;
  - Failure to recognize the need of exit the room;
  - Unawareness of impending hazard;
  - Fatal damage of pregnant women;
  - Physical inability to exit the room; and
  - Unconsciousness
- Do not take a sauna if using alcohol, drugs or medications.
  - Pregnant women or persons with poor health should consult their physician before using any sauna.
  - Caution fire hazard: Do not use the sauna room for drying clothes, bathing suits, etc. Do not hang towels above heater or place any object other than the rocks supplied on the heater. If any darkening of the wall around the heater is noticed discontinue sauna use immediately.
  - Inspect sauna regularly for required maintenance to heater, control and benches. Replace wood surfaces which show any signs of deterioration.
  - The heater gets extremely hot during operation and should not be touched or burns may result.
  - Minors should be adequately supervised whenever near a hot or warming sauna.
  - Fire sprinkler systems used inside any sauna room should be properly rated for sauna room temperatures.
  - Do not pour chlorinated pool or spa water on heater. Excessive water use on heater may cause damage and void warranty.
  - This appliance is not intended for use by persons (including children) with reduced physical, sensory or mental capabilities, or lack of experience and knowledge, unless they have been given supervision or instruction concerning use of the appliance by a person responsible for their safety. Children should be supervised to ensure that they do not play with the appliance.

- Electric Shock Hazard - High voltage exists within this equipment. There are no user serviceable parts in this equipment. All installation and service to this equipment should be performed by qualified licensed personnel in accordance with local and national codes.
- Do not construct sauna room so as to restrict air flow through the bottom of the heater.
- Packing the rocks too tightly may cause the heater high limit switch to trip.
- Maintain minimum clearance from heater to wooden surfaces (benches, side walls, heater fence etc.). Mounting brackets supplied. Provides proper clearance from wall behind heater.
- Use only copper wire of the size and type indicated in the Heater Specification Chart and the temperature rating indicated on the heater junction box.
- A guardrail or fence is required around the heater to prevent burns from accidental contact.
- All heaters and controls must be grounded per NEC to prevent electrical shock in case of unit failure.
- Electrical outlets or receptacle must not be installed in a sauna room.
- Do not locate benches over heater.
- For household only.



Keep this user guide!

In the event of any problems, please contact the retailer where you purchased the equipment.



# INSTALLATION GUIDE

## BEFORE INSTALLATION

### Parts

Check that the following parts are included in the packaging:

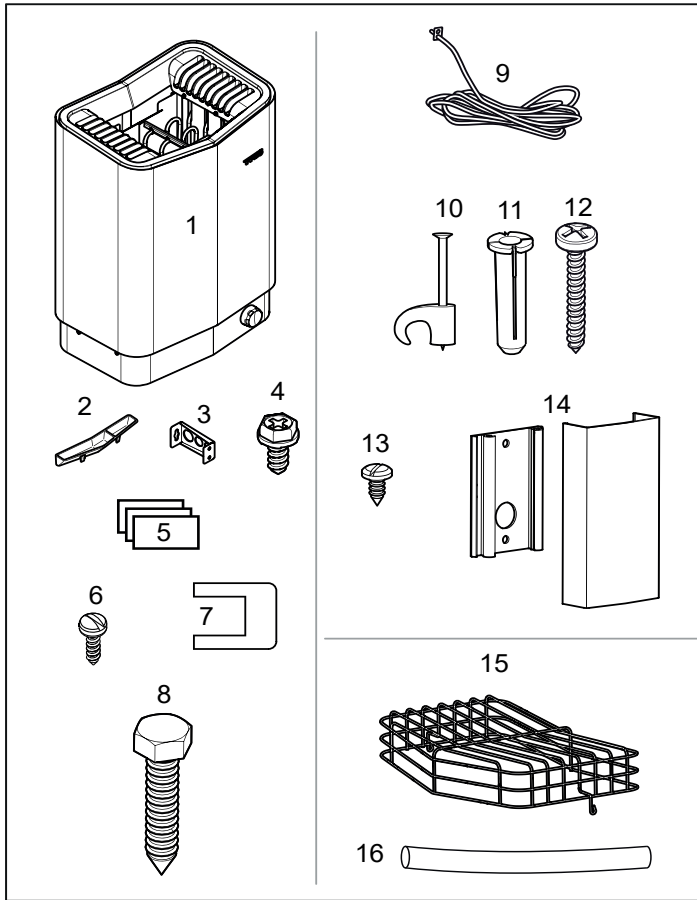

Figure 1: Sauna heater/control panel parts

1. Sauna heater
2. Herb bowl/air humidifier
3. Brackets x 4
4. Lock screw B8x9.5 x 1
5. Warning and Caution plates for the room in multiple languages
6. Screws B 4 x 6.5 x 6 for Warning and Caution plates
7. Connectors x 3
8. Bracket screws x 4
9. NTC Sensor, cable length 4 m
10. Clips TC (3-5) x 10 pieces
11. Plastic plugs 25x5 x 2 pcs
12. Screws B6x25 x 2 pcs
13. Screw B4x6,5 x 1 piece
14. Sensor cover
15. Rock guard
16. Protection hose Ø14x150 mm x 3 pcs, for RJ10 cables (sensor, control panel, door switch)

Contact your dealer if anything is missing.

### Installation requirements

To ensure safe use of the heater, check that the following criteria are met:

- Electrical wiring should be installed in accordance with NEC and all state and local codes.
- Fuse size (A) and power cable size (AWG) must be suitable for the heater (see The section called Connection/wiring diagram, Page 8).
- The sauna ventilation must comply with the instructions in this manual (see The section called Positioning the inlet vent, Page 5, The section called Positioning the outlet vent, Page 5).
- The position of the sauna heater, control panel, and sensors must comply with the instructions in this manual.
- The heater output (kW) must be suitable for the sauna volume (cu.ft.) (See Table 1, Page 3). The minimum and maximum volumes must not be exceeded.
- NOTE: A GFCI device is not required by ETL. A GFCI may be installed if required by local codes. However, GFCI devices will tend to nuisance trip during use of the product.

Table 1: Voltage and sauna volume

Model	Voltage	kW	Sauna volume min. cu.ft.	Sauna volume max. cu.ft.
Sense U 7 Elite/Pure (SPU7)	208 V	5,3	130	175
	240 V	7,0	130	320
Sense U 8 Elite/Pure (SPU8)	208 V	6,3	195	285
	240 V	8,3	195	440

### Installation tools

The following tools and materials are needed for installation and connection:

- level
- tape measure
- electric drill
- screw drivers

### Installation planning

Before starting to install your sauna heater:

- Plan the sauna heater positioning (see the Heater positioning - normal installation section, page 4).
- Plan the control panel positioning (see the attached instructions for the control panel for allowable positioning).
- Plan the sensor positioning (see Figure 3, page 4).
- Position the air intake vent (see the Air intake vent positioning section, page 5).
- Position the air exhaust vent (see the Air exhaust vent positioning section, page 5).
- Plan the electrical installation (see the Connection/wiring diagram section, page 8).

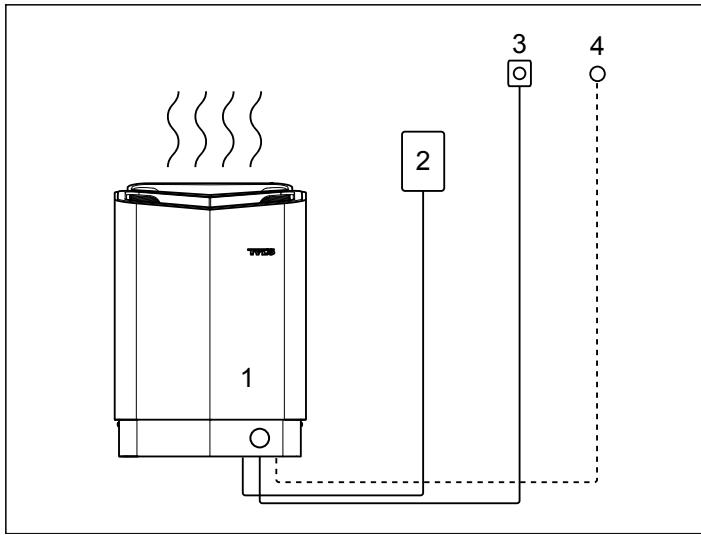

Figure 2: Schematic diagram of installation

1. Sauna heater
2. Control panel
3. Sensor
4. External on/off switch (option, door contact needed for function)



**DANGER!** No more than one heater may be installed in the same sauna cabin.

### Positioning the control panel

The control panel can be installed inside or outside of the sauna room.

The control panel must be correctly positioned with regard to safety distances below when installed inside the sauna room

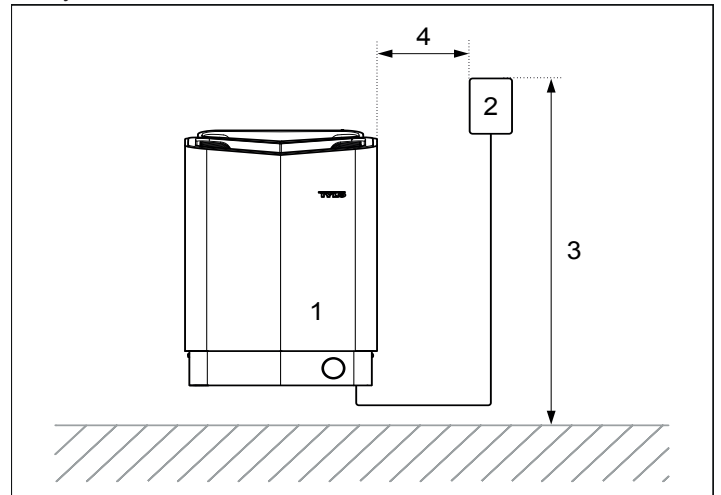

Figure 4: Safety distance, control panel

1. Heater
2. Control panel
3. Max. 36 in
4. Min. 12 in

### Positioning the heater - normal installation

Position the sauna heater:

- on the same wall as the door (or the side wall if very close to the door wall).
- Position the heater at a safe distance from the floor, side walls and interior fittings (see Figure 3).

Position the sensor according to the picture (see Figure 3).

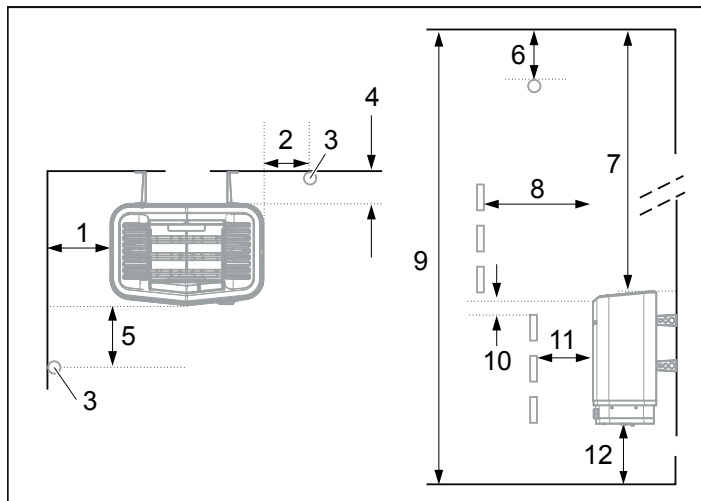

Figure 3: Positioning the heater - normal installation

1. Minimum distance from side wall: 3 in
2. Sensor position (option 1): 3 in from heater
3. Sensor
4. Minimum distance from back wall (with legs): 4 in
5. Sensor position (option 2): 3 in from heater front
6. Sensor position: 1 in from ceiling
7. Minimum distance from ceiling: 44 in
8. Minimum distance from interior fittings: 4 in
9. Minimum ceiling height: 75 in
10. Minimum distance: 1 in
11. Minimum distance from interior fittings: 2 in
12. Suggested distance from floor: 7 in



**WARNING**

REDUCE THE RISK OF OVERHEATING

- \* Exit immediately if uncomfortable, dizzy, or sleepy. Staying too long in a sauna is capable of causing overheating.
- \* Supervise children at all times.
- \* Check with a doctor before use if pregnant, in poor health, or under medical care.
- \* Breathing heated air in conjunction with consumption of alcohol, drugs, or medication is capable of causing unconsciousness.



**CAUTION**

REDUCE THE RISK OF FIRE

Do Not Place Combustible Material On The Heater At Any Time.

Figure 5: Warning/Caution plate

### Sauna room ventilation

In a sauna, the air should be changed about 6 times an hour. See Figure 6.

It is recommended that ventilation openings meet the requirements of UL Specification 875. The minimum opening should be determined using one of the following formulas:

$$\text{For } R < 31, \quad V \geq 9.3$$

$$\text{For } R \geq 31, \quad V \geq 0.3 * R$$

where  $R$  = the floor area of the room in square feet and  
 $V$  = the minimum vent size in square inches

#### Example Venting Calculation:

Room is 54 sq.ft. (9 ft. by 6 ft.) 54 is larger than 31.

Multiple  $54 \times 0.3 = 16.2$  sq. in.

Vent size opening should be 4 in x 4 in.

### Positioning the inlet vent

Install the inlet vent straight through the wall under the centerline of the heater.

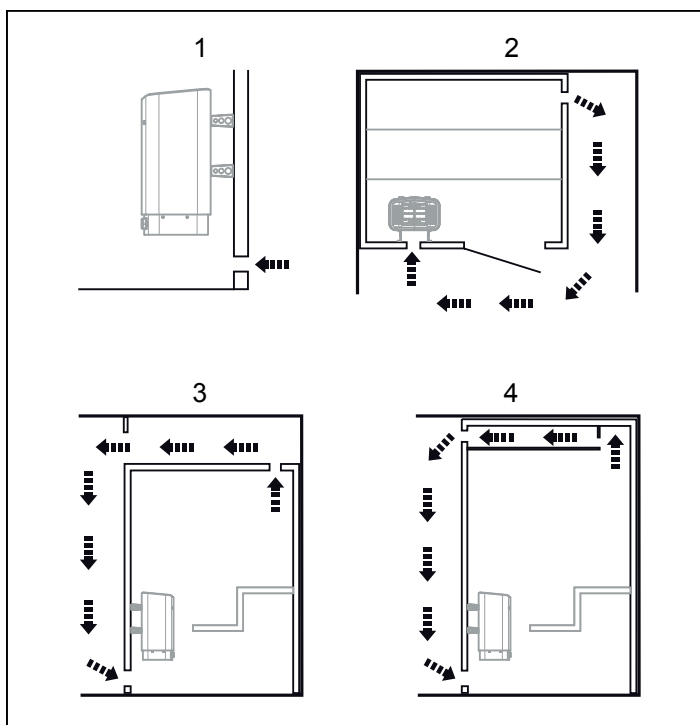

Figure 6: Positioning the air intake and exhaust vents

1. Inlet vent position.
2. Outlet vent position through the sauna wall.
3. Outlet vent position through the cavity.
4. Outlet vent position via duct.

### Positioning the outlet vent

Position the outlet vent

- at the maximum possible distance from the air intake vent, e.g. diagonally (see Figure 6).
- high on the wall or in the ceiling (see Figure 6).
- so that it vents into the space that the door and air intake vent open into.

The outlet vent must have the same area as the inlet vent.

Ensure that the outlet vent is open.

Mechanical ventilation is not recommended due to the risk of poor air exchange, which can negatively affect the heater temperature cut-out.

### Removing the Rock Guard

Unscrew the two screws on the side of the heater and lift the rock guard upwards, see Figure 7. (This is necessary when filling the stone compartment or cleaning the fragrance holder and air humidifier).

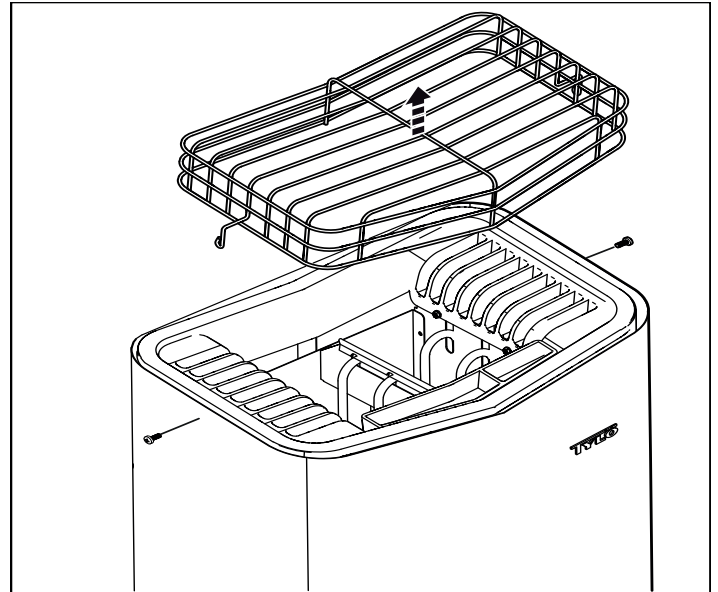

Figure 7: Removing the Rock Guard

### Room construction

For safety and reliability, the following rules must be addressed.

- The enclosed WARNING: Reduce the risk of overheating the warning plate must be mounted on or alongside the door outside the sauna room at about eye level. Use the supplied screws.
- The enclosed CAUTION: Reduce the risk of fire, the caution plate must be mounted on the interior wall above the heater. Use the supplied screws.
- No permanent locking or latch system is to be used on the sauna door.
- Acceptable door fittings are: magnetic catches, friction catches, spring or gravity loaded closures. The door must always open outwards.
- No shower may be installed in a sauna room.
- No electrical receptacle shall be installed inside the sauna room.
- The heater should not be operated without its container properly filled with rocks and the rock guard in place.
- If an intercom speaker is installed, it should be away from the heater and as close to the floor as possible.
- If a room light is installed, it should be a surface mounted bracket type. Wall mounted lights should be about 70" above the floor. Ceiling mounted lights should be of an approved type with a junction box that is remote to the fixture itself. Use only a fixture that uses A.F. or fixture type internal wiring. A 60 watt bulb should provide sufficient lighting.
- Fire sprinkler systems installed inside any sauna room should be properly rated for sauna room temperatures.
- Always mount the heater according to these installation instructions.



## Typical wall construction

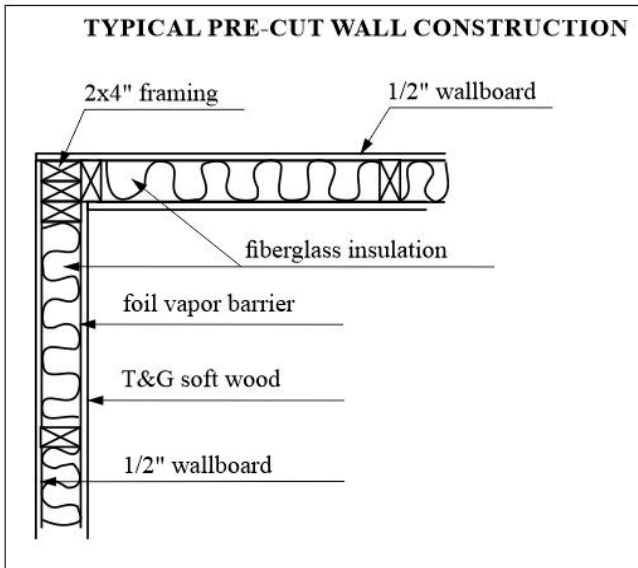

Figure 8: Typical wall construction

## INSTALLATION

### Sauna heater installation

It is easiest to prepare for installation with the heater lying down. To install the heater:

1. Lay the heater down with the front facing upwards.
2. Undo the screws and open the cover (see Figure 9).

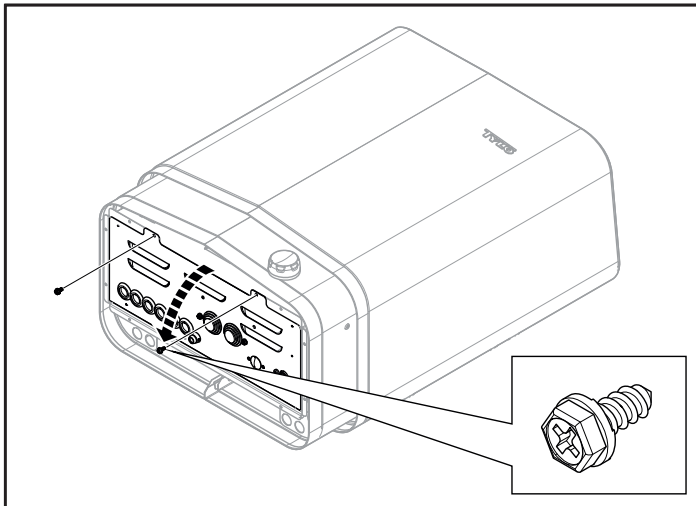

Figure 9 Opening/closing the cover



**WARNING! Always check that the heater is connected to the correct main/phase voltage!**

Connect the heater using 90°C approved rated wire for fixed installation. Installed shall be in accordance with NEC and State and local codes.

3. Connect the electrical cable (1) to the terminal (2) (see Figure 10) according to the wiring diagram (see the Connection/wiring diagram section, page 8).
4. Run the cables for the control panel and the temperature sensor through the cable grommets (3). Connect the control panel cable (4) to one of the four RS485 contacts (positions 6-9) (see Figure 10) according to the wiring diagram (see the Connection/wiring diagram section, Fig 18 page 8).
5. Connect the humidity- and temperature sensors cable (6) to one of the four RS485 contacts (positions 6-9) (5) according to the wiring diagram (see the Connection/wiring diagram section, Fig. 18 page 8).

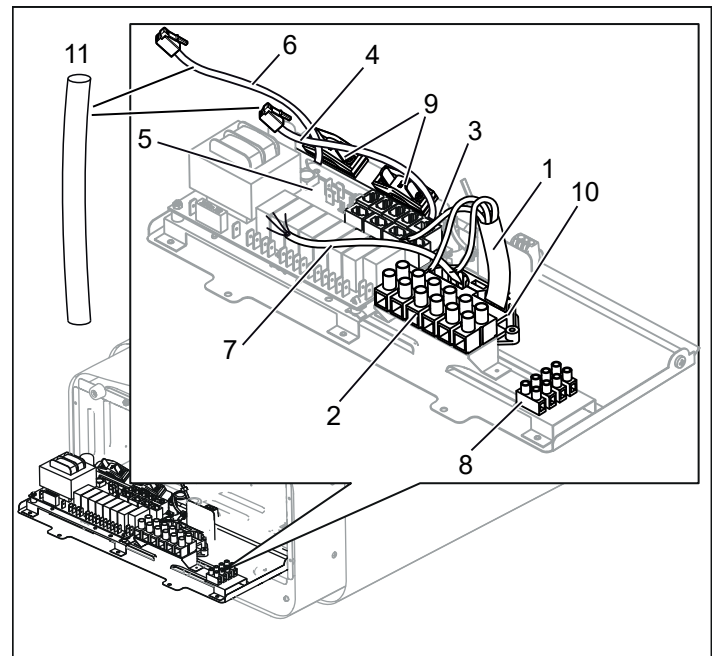

Figure 10: Circuit board

- |                                                                  |                                                                |
|------------------------------------------------------------------|----------------------------------------------------------------|
| 1. Electrical cable                                              | 7. Light cable (if connected)                                  |
| 2. Terminal for connection of electrical cable                   | 8. Terminal for connection of light (if connected)             |
| 3. Cable grommet (x6)                                            | 9. Strain relief connector for cables to modular contacts (x2) |
| 4. Control panel cable                                           | 10. Strain relief connector for electrical cable               |
| 5. Modular contacts for connection of control panel, sensor etc. | 11. Protection hose for RJ10 cables                            |
| 6. Sensor cable                                                  |                                                                |
6. Connect the light cable (if used) (7), see Figure 10, to the terminal (8) according to the wiring diagram Figure 18.
  7. Close the cover and tighten the screws (see Figure 9).



**NB: If all the screws on the back are unscrewed simultaneously, the back plate may come loose. For this reason, attach the four brackets to the heater one at a time.**

8. Unscrew the first two screws on the back of the heater and screw one of the four brackets into place. Repeat the procedure until all of the brackets are fitted see Fig. 11.

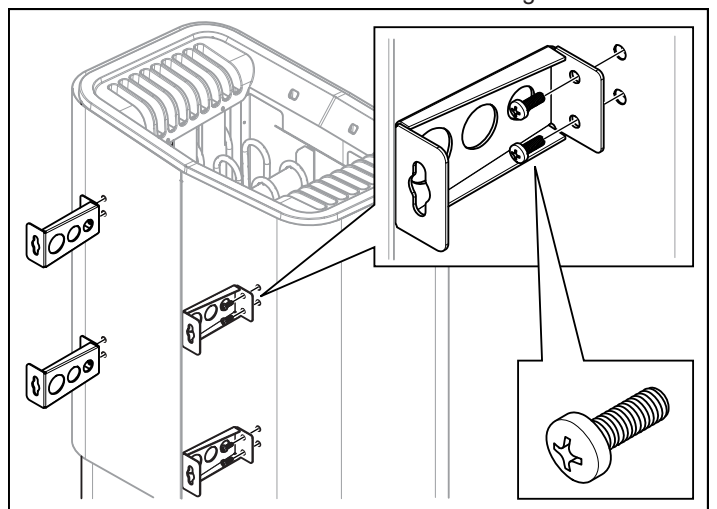

Figure 11: Attaching the brackets to the heater

9. Position the bracket screws according to the specified dimensioning see Fig. 12.

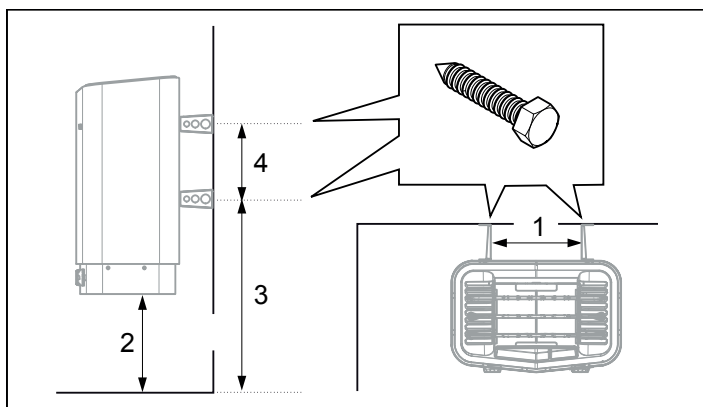

Figure 12: Dimensioning

1. 10.31 in
2. 6 in
3. 16.3 in
4. 8.11 in

10. Fit herb bowl/air humidifier (see Fig. 13).

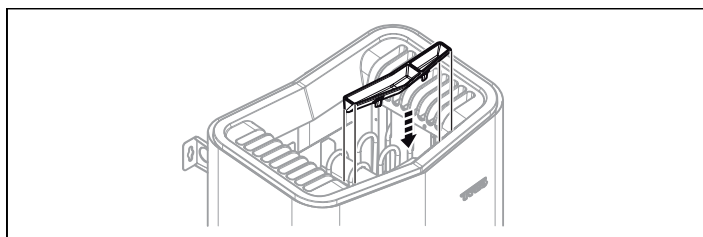

Figure 13: Fitting the fragrance holder/air humidifier

11. Hang the heater on the screws see Fig. 14.

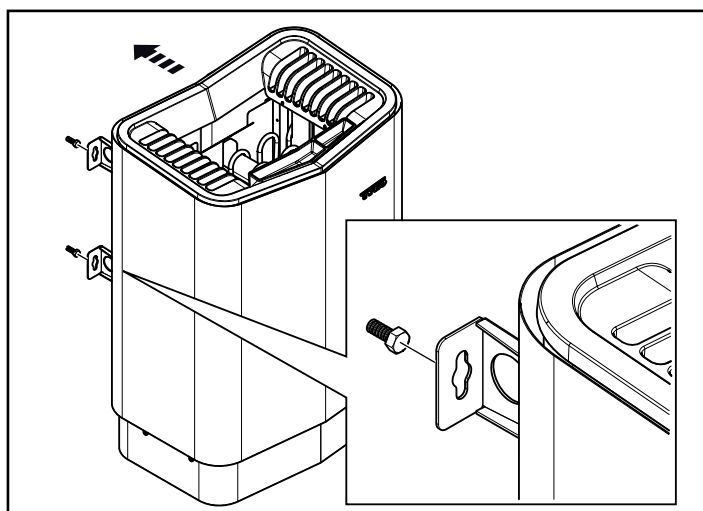

Figure 14: Hang the heater up.

12. Lock the heater into place with the lock screw see Fig. 15.

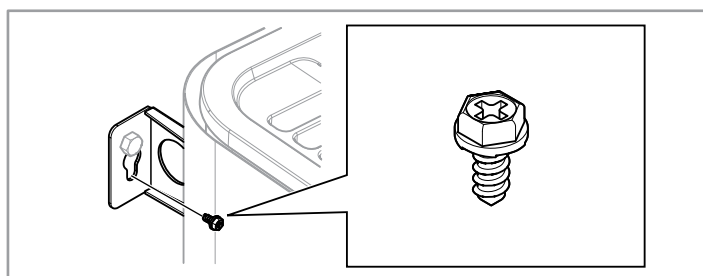

Figure 15: Lock screw for bracket

13. Install the sensor on the wall see Fig 16. The thermistor wire may also be passed through the wall. Seal any holes in the wall behind the sensor, see Figure 17. The thermistor wire may be extended outside the sauna using low voltage wire (2-lead).

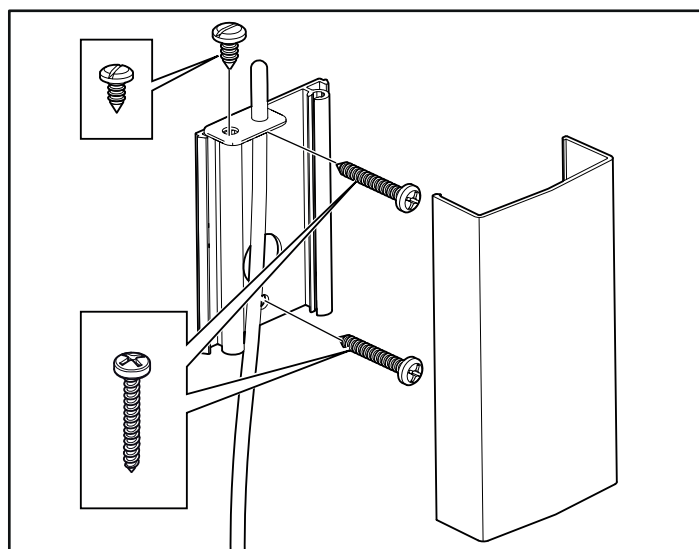

Figure 16: Installing the sensor

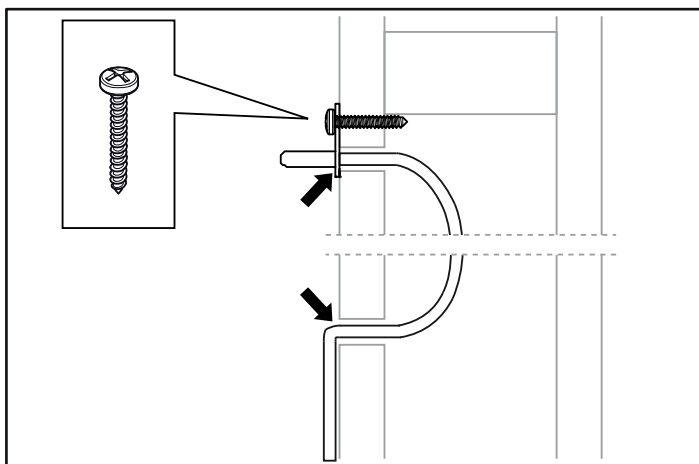

Figure 17: Seal any holes

#### Unusual voltages/numbers of phases

Contact Tylö Customer Service before connecting to voltages or numbers of phases that are not listed in the wiring diagram Figure 18.

#### External ON/OFF switch (option)

The external ON/OFF switch can be positioned anywhere outside the sauna, not to exceed 75 feet from the heater, to avoid voltage loss in the cable. Voltage loss affects the LED indicator for heater status (if built-in and connected to the switch).

For further information, see instructions supplied with the control panel.

## CONNECTION/WIRING DIAGRAM

TAB	208 V 1 Phase			240 V 1 Phase		
Model	Amperage Amps	Output kW	Wire Size AWG	Amperage Amps	Output kW	Wire Size AWG
Sense U 7 Pure/Elite	26	5,3	10	30	7,0	8
Sense U 8 Pure/Elite	30	6,3	8	35	8,3	8

**Note:** Heating elements do not change for voltage changes. The heater output will be changed based on the voltage applied to heater.

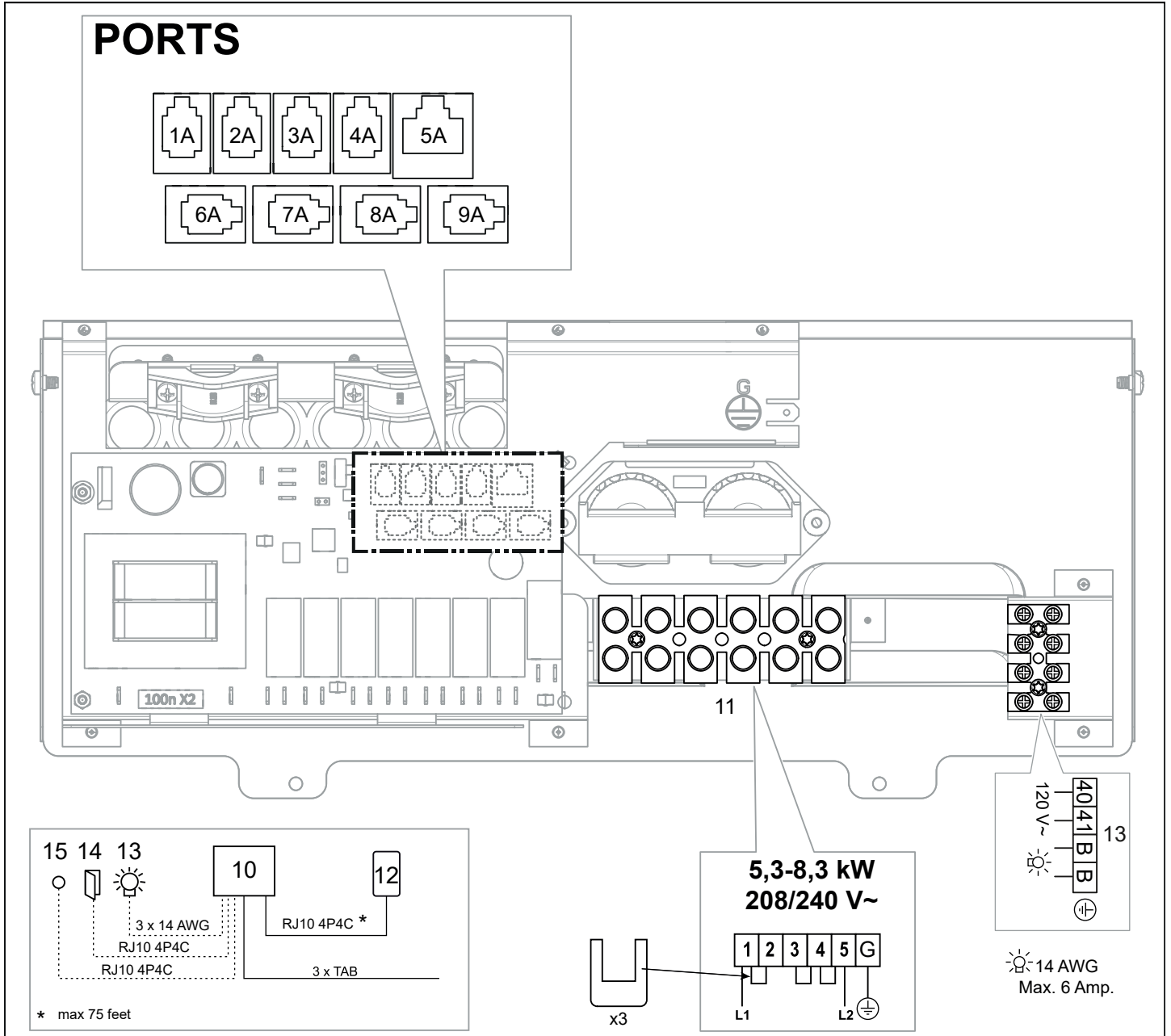

Figure 18: Wiring diagram

- |                                           |                                                 |
|-------------------------------------------|-------------------------------------------------|
| 1A. NTC Sensor                            | 10. Heater                                      |
| 2A. Ext switch (External switch optional) | 11. Terminal for connection of electrical cable |
| 3A. N/A                                   | 12. Control panel                               |
| 4A. N/A                                   | 13. Light/terminal for connection of light      |
| 5A. N/A                                   | 14. Door contact (option)                       |
| 6A. N/A                                   | 15. External switch (option)                    |
| 7A. N/A                                   |                                                 |
| 8A. N/A                                   |                                                 |
| 9A. Controls Elite/Pure                   |                                                 |



Description of cabling/modular contacts

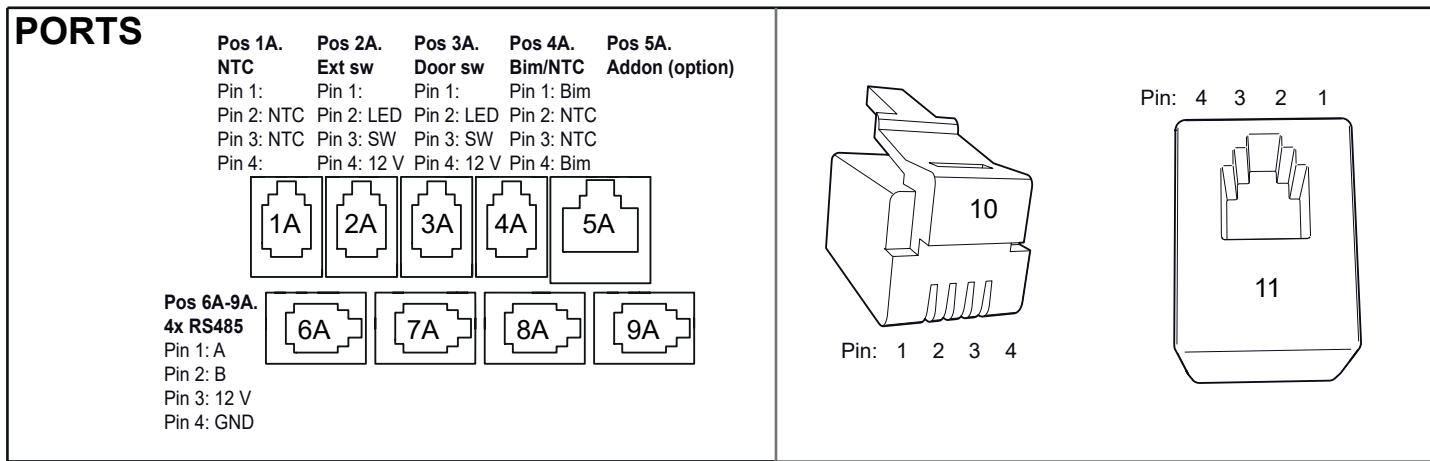

Figure 19: Modular contacts, description

(Pos 1-4 and 6-9: RJ10, Pos 5: RJ45)

- 1A. NTC Sensor
- 2A. Ext switch (optional)
- 3A. N/A
- 4A. N/A
- 5A. N/A
- 6A. N/A
- 7A. N/A
- 8A. N/A
- 9A. Controls Elite/Pure
- 10. Modular plug (RJ10)
- 11. Modular contact (RJ10)

Table 3: Connecting components in modular contacts (maximum cable area for RJ10: 0.90 mm/0.20 mm<sup>2</sup>, AWG24)

Connection of	Pos	Pin	Comment
Temp. sensor (10kohm)	1 A	2-3	Must be NTC model.
External switch with no wire indicator	2 A	3-4	Both constant or impulse deactivation works.
External switch with wire indication	2 A	2-3-4	12VDC (max. 40mA).

**NOTE!** Crimp pliers are needed if changing modular cabling, e.g. shortening wires.

**SELF-INSPECTION OF THE INSTALLATION**

To check the installation:

1. Turn power on at the Circuit Breaker Box.
2. Check that the control panel lights up.
3. Start the heater (see User Guide).
4. Check that all three tubular elements start to heat up (go red).

Please keep these instructions!  
In the event of problems, please contact the retailer where you purchased the equipment.  
© This publication may not be reproduced, in part or in whole, without the written permission of Tylö. Tylö reserves the right to make changes to materials, construction and design.

DIMENSIONS

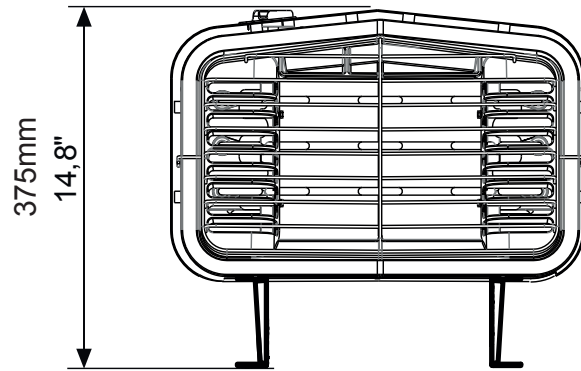
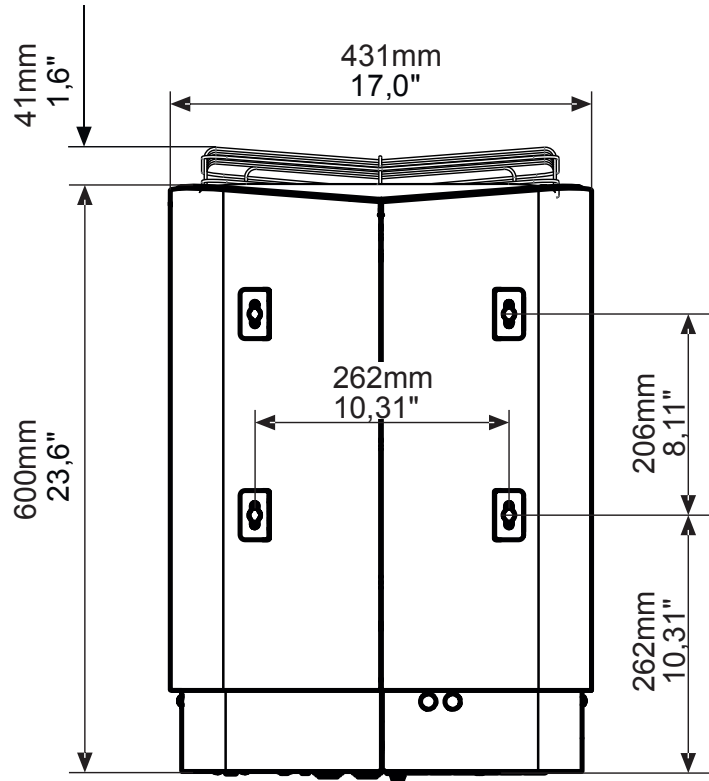

## USER GUIDE

### GENERAL INFORMATION

Congratulations on your new sauna heater! Follow this user guide to get the most from your purchase.

Wet and dry saunas are forms of bathing which originate way back in history. A hot sauna is best enjoyed at temperatures between 145-190°F.

### PRIOR TO USE

#### The first time you use the heater

Fill the stone compartment



**NB: Always use dolerite stones (Tylö Sauna Stones)! "Ordinary" stones may damage the heater. Do not use ceramic stones. Ceramic stones may damage the heater. The heater guarantee does not cover damage caused by ceramic stones.**

Fill the stone compartment around the heating elements from the bottom to the top, to approx. 2" above the top front edge. Do not press the stones into place. Capacity: Approx. 35 lb of stones. Place the stones loosely to allow optimum air circulation. The tubular heating elements must not be squeezed together or against the side.

Sauna stones must:

- tolerate extreme heat and fluctuations caused by water being poured on them.
- be cleaned before use.
- must have an uneven surface, so that the water "clings" to the stone surface and evaporates efficiently.
- be between 1-1/2" to 2" in size to allow air circulation in the stone compartment. This will increase the life of the tubular elements.



**NB: Never place stones on top of the side air chambers. This way will obstruct air circulation, causing the unit to overheat and the cut-out switch to activate.**

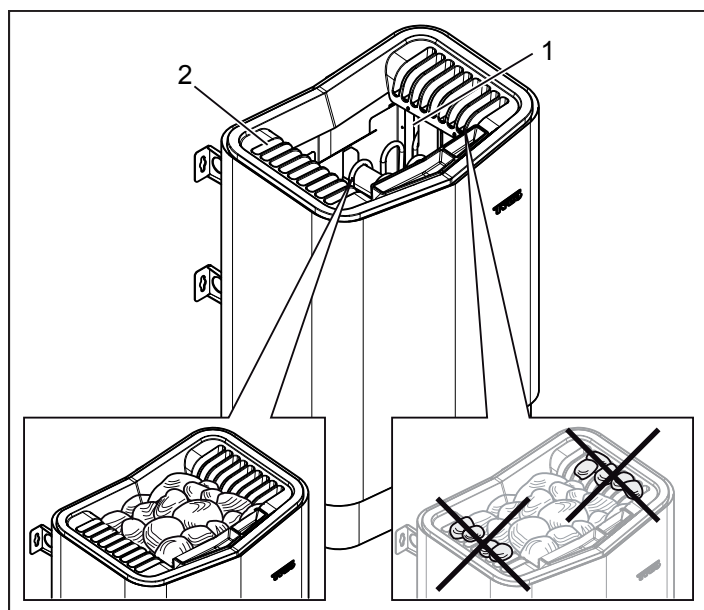

Figure 1: Filling the stone compartment

1. Stone compartment
2. Side chambers

Turn on the heater to remove any new paint odors

To remove "new paint odor" from the heater:

Heat the sauna heater for about one hour. The water reservoir does not need to be working.

A little smoke may appear.

### Default settings

Using the control panel for the first time:

See instructions supplied with the control panel.

### Prior to each use

Check the following

Check that:

- there are no foreign objects in the sauna cabin, on or in the heater.
- the door and any windows to the sauna cabin are closed.
- that the sauna door opens outwards with a little pressure.

**NB:**



**DANGER! Fragrant essences and similar products may ignite, if poured directly onto the stones.**



**NOTE! Do not use the sauna cabin for any purpose other than taking saunas.**

### Turn on the main power switch

The main power switch is at the bottom of the heater.

Switch it on, if it is not already switched on (see Figure 2).

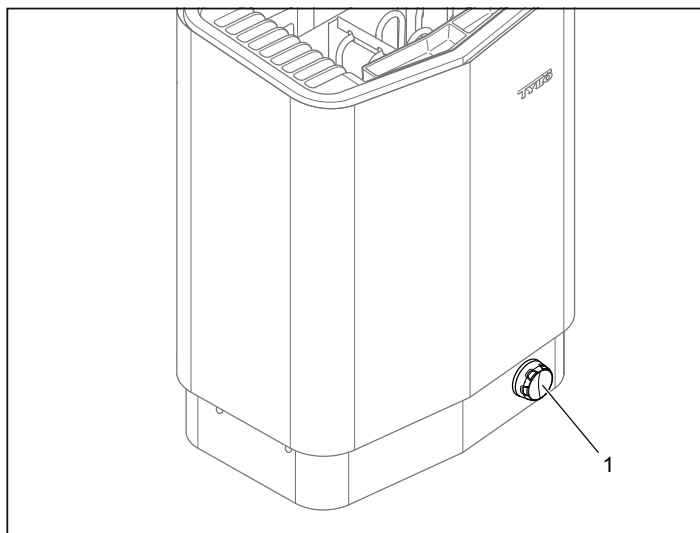



Figure 2: Positioning of the main power switch

1. Main power switch

**The control panel in general**

See instructions supplied with the control panel.

**Fragrance holder**

 **DANGER! Fragrant essences etc. may ignite if poured directly onto the stones.**

To create a pleasant fragrance in the sauna, pour a few drops of Tylo Sauna Fragrance into the water in the fragrance holder. You can also mix a few drops of the sauna fragrance with water in a sauna bucket and pour the water on fully heated stones. Use a sauna ladle for pouring water on the hot stones.

Tylo Sauna Fragrance comes in different variants and fragrances. Go to [www.tylo.com](http://www.tylo.com) to see the full range.

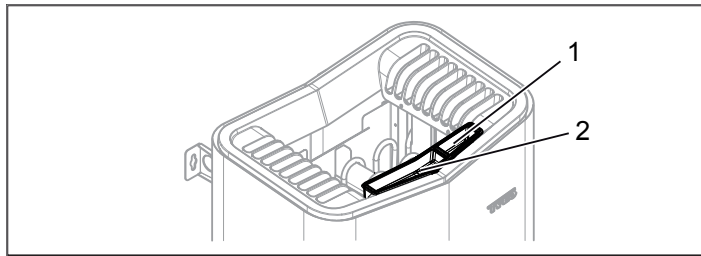



Figure 3: Other functions

- 1. Fragrance holder
- 2. Air humidifier

**Air humidifier**

 **DANGER! Do not pour water into the fragrance holder once it has been heated up, as this can cause boiling water to splash on the sauna occupants. Do not stand or sit in front of the heater while water is being poured into the fragrance holder, as hot water can spray out suddenly.**

To maintain a comfortable basic level of humidity in the sauna, fill the built-in air humidifier (see Fig. 3) with water before switching on the sauna.

 **Tip: Pour a few drops of diluted sauna fragrance into the built-in air humidifier.**

**AFTER USE**

**Switch off the main power switch.**

The main power switch is at the bottom of the heater. Switch off here when the heater is not to be used for an extended period (e.g. several weeks).

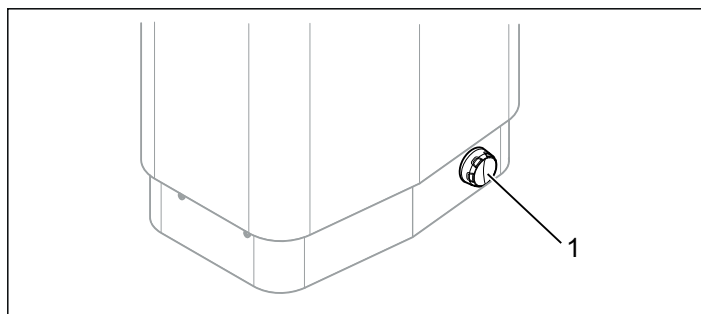

Figure 4: Positioning of the main power switch

**MAINTENANCE**

**Cleaning the fragrance holder and air humidifier**

Clean the fragrance holder and air humidifier as required. To clean the fragrance holder and air humidifier: Remove the fragrance holder/air humidifier and rinse them under running water.

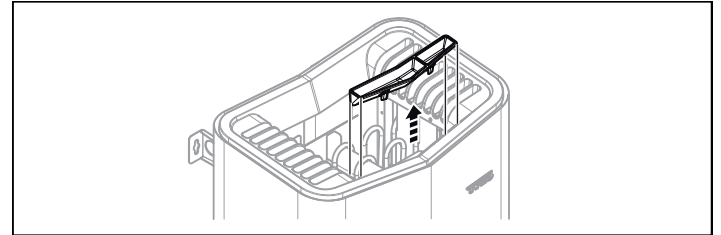



Figure 5: Cleaning the fragrance holder and air humidifier

**Check the stone compartment**

Check the stone compartment at least once annually or as many times per year as the heater is used per week. Example: If the unit is used 3 times a week, check the stone compartment 3 times per year.

 **WARNING! If the stone compartment fills up with gravel and small stones, the tubular element can be damaged as a result of overheating, as air flow will be insufficient.**

How to check the stone compartment:

1. Remove all stones from the compartment.
2. Remove any small stones, gravel and limescale from the compartment.
3. Put whole, undamaged stones back. Replace damaged stones with new ones as required (see Filling the stone compartment, page 5).

**EXTERNAL ON/OFF SWITCH (OPTION)**

External ON/OFF switch can be installed anywhere outside the sauna. The switch is momentary pulse or constant activation. The heater circuit automatically recognises which is used. Heater status and faults on the door contact can be seen if the switch has a built-in LED.

See instructions supplied with the control panel.

## TROUBLESHOOTING

### Temperature Safety Switches

The heater's temperature protection devices:

- **PCA** - The temperature safety on the PCA in the heater is designed to prevent components being damaged by overheating. If the safety switch is triggered, an error code shows on the control panel display.

If the overheating switch has activated, the heater cannot be started again until the temperature has dropped down 68 degrees (°F) on the PCA.

- **Heater** - The temperature cut-out in the heater protects the components and woodwork in the sauna from overheating. There is a white reset button on the left side of the heater which must be pressed in (see Fig. 9). If the heater safety switch has activated, the button will feel stiff and will 'click' when reset.

### Information!

When the overheating safety switches activate, always check the cause of the problem. The life of the elements and PCA can be adversely affected by each overheating. If systems continues to overheat look at the following: Ventilation deficient? Room volume? Internal heater fault?

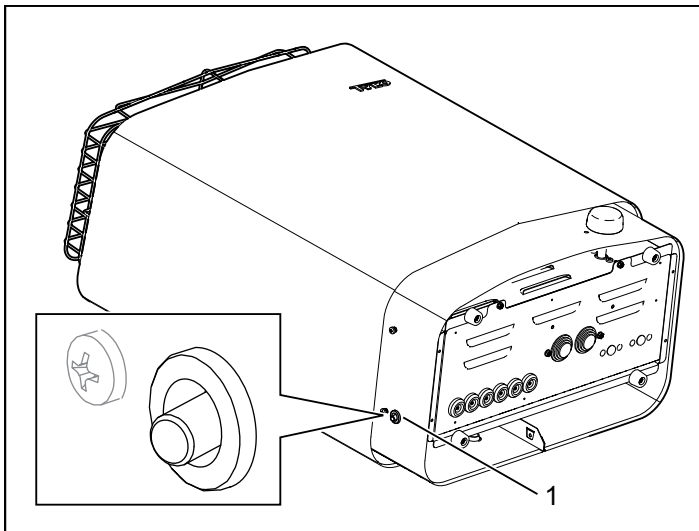

Figure 6: Resetting the temperature cut-out

1. Temperature cut-out sauna heater

### Troubleshooting the control panel

See instructions supplied with the control panel.



## Troubleshooting the sauna heater

### Information!

Contact the dealer during the guarantee period in the event of faults.

See the instructions for the control panel for details of faults not covered in this user guide.

Table 1: Troubleshooting the sauna heater

Symptom	Possible cause	Remedy
Heater element in heater stone compartment does not warm up.	<ol style="list-style-type: none"> <li>1. Temperature settings on control panel do not correspond to operating status?</li> <li>2. Water reservoir in operation? Only two of the three heater elements in the stone compartment can operate at the same time as the tank, otherwise excessive current is drawn from the electricity supply. This is not a fault outside normal operation.</li> <li>3. Some of the heater fuses on the main switchboard can have tripped out?</li> <li>4. Resistor coil in the heater element faulty?</li> <li>5. Internal heater PCB fault?</li> </ol>	<ol style="list-style-type: none"> <li>1. Set temperature to correspond to heater element operation in stone compartment.</li> <li>2. See the instructions supplied with the control panel.</li> <li>3. Check and replace/reset the fuses in the main switchboard.</li> <li>4. An authorised electrician is required to find the fault.</li> <li>5. An authorised electrician is required to find the fault.</li> </ol>
Lights in the sauna do not come on when switched on at the control panel.	<ol style="list-style-type: none"> <li>1. Is lighting connected via the heater?</li> <li>2. Internal heater PCB fault?</li> </ol>	<ol style="list-style-type: none"> <li>1. Verify with authorized electrician who performed installation of heater/lighting.</li> <li>2. An authorized electrician is required to find the fault.</li> </ol>
Heater does not work, control panel does not light up.	<ol style="list-style-type: none"> <li>1. The main power switch is off?</li> <li>2. Circuit breaker tripped on main electrical panel.</li> <li>3. Loose contact in cabling between heater and control panel?</li> <li>4. The specific 12VDC output on one of the PCB's RS485 modular jack to the control panel is faulty due to short-circuit?</li> <li>5. Transformer on PCB in heater faulty?</li> <li>6. Control panel faulty?</li> </ol>	<ol style="list-style-type: none"> <li>1. Turn heater main power switch.</li> <li>2. Check and replace/reset the fuses in the main switchboard.</li> <li>3. Switch off heater main power switch and connect each/paired cable to the control panel. Switch on heater main power switch again. If this does not help, an authorized electrician is required to find the fault.</li> <li>4. Requires an authorized electrician to find the fault, faulty 12VDC output is indicated by LED out next to the RS485 output. Note: if the fault is in the RJ10 cable to the control panel, do not click into a working vacant RS485 outlet to avoid causing a fault in that outlet. RJ10 cable must be replaced/ contacts fitted in the event of a fault.</li> <li>5. An authorized electrician is required to find the fault.</li> <li>6. An authorized electrician is required to find the fault.</li> </ol>
The fuses or circuit breaker in the building breaker panel trips as soon as the heater is turned on.	<ol style="list-style-type: none"> <li>1. There is a short-circuit at the heater GND. Can be due to a faulty heater element?</li> <li>2. Lighting connected to and controlled via the heater faulty?</li> <li>3. The heater has not been used for a long period, causing an insulation fault in the heater element?</li> <li>4. Heater has had too much water poured on it?</li> <li>5. Other internal heater fault?</li> </ol>	<ol style="list-style-type: none"> <li>1,2,3,4,5. Do not use the heater, switch off at main heater main switchboard trip and disconnect heater fuses on the main switchboard. An authorized electrician is required to find the fault.</li> </ol>

## SPARE PARTS LIST

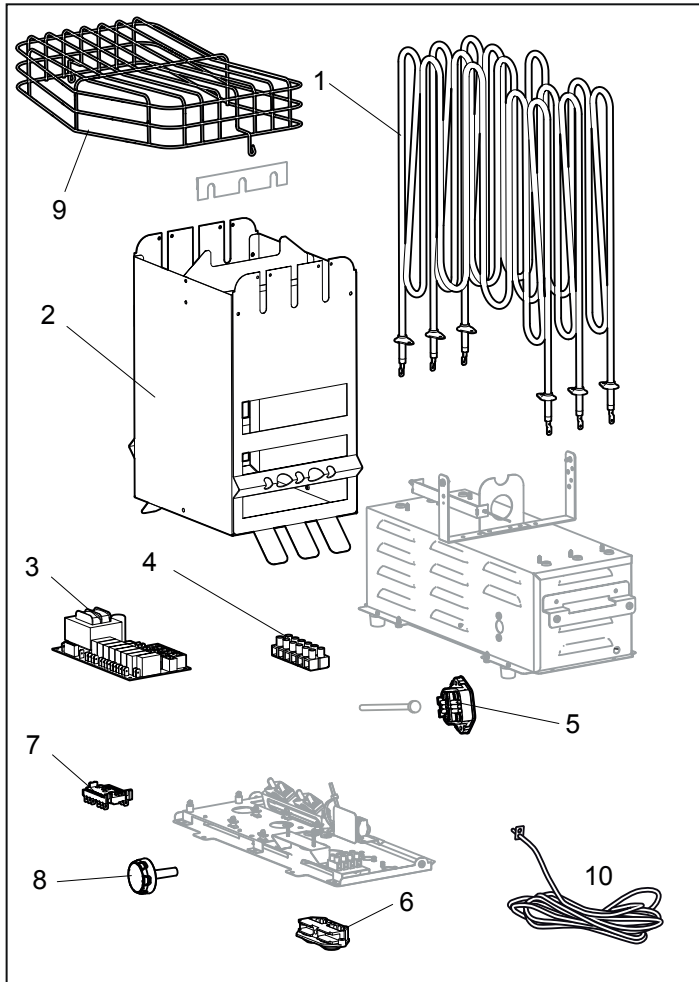

Figure 7: Spare parts 1

1.	U8 Pure/Elite Tubular Elements	3001-924/9600 0158
	U7 Pure/Elite Tubular element	3001-920/9600 0243
2.	Stone compartment	9600 0735
3.	Circuit board Elite	9600 0068
	Circuit board Pure	9600 0067
4.	Terminal block	9600 0723
5.	Sauna heater temperature safety switch	3119-607/9600 0253
6.	Strain relief connector	9600 0554
7.	On/Off Switch	9600 0040
8.	On/off dial	9600 0132
9.	Rock Guard	8019-541/9600 0736
10.	NTC Sensor	9600 0219

## ROHS (RESTRICTION OF HAZARDOUS SUBSTANCES)

Instructions for environmental protection:

Do not dispose of this product with the domestic refuse when no longer in use. Take it to a recycling station for electrical and electronic equipment instead.

For further information, see the symbol on the product, manual or packaging.

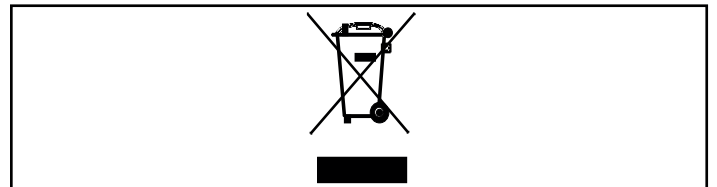

Figure 8: Symbol

The different materials can be recycled as specified by their labelling.

You can help protect the environment by recycling or reusing the spent appliances or the materials in them. Take the product to a recycling centre without the sauna stones or the soapstone jacket (if fitted).

Contact your local authorities for details of your nearest recycling centre.

Please keep these instructions!

In the event of problems, please contact the retailer where you purchased the equipment.

© This publication may not be reproduced, in part or in whole, without the written permission of Tylö. Tylö reserves the right to make changes to materials, construction and design.

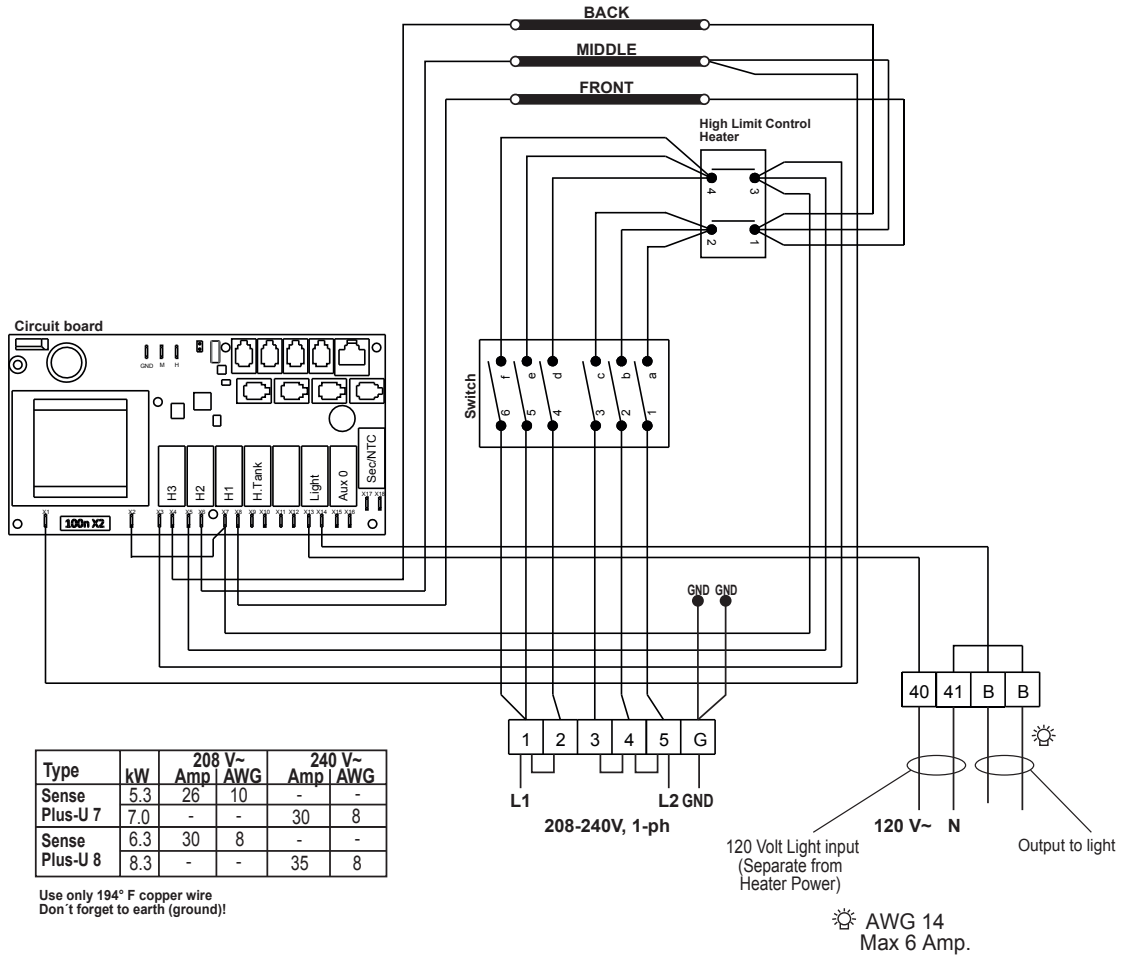



# SaunaFin

Saunas & Steambaths

## SAUNAFIN SAUNA & STEAM

106 Rayette Road, Unit 1, Concord, ON, L4K 2G3

### TOLL-FREE

1-800-387-7029

### PHONE

905-738-4017

### EMAIL

[info@saunafin.com](mailto:info@saunafin.com)

### WEB

[www.saunafin.com](http://www.saunafin.com)